

Compliant  
with new  
IMO 2008 regulations

# CHARTPILOT 1100

## The ECDIS Solution



The versatile approved ECDIS  
Electronic Chart Display and Information System



**SAM**  
**Electronics**

an  communications company

# Safe Navigation

The CHARTPILOT\* assists the operator in all navigation and manoeuvring tasks. The system is an approved ECDIS, navigation and planning system which can also be part of an integrated navigation system.

All CHARTPILOT functions are in compliance with the latest ECDIS Performance Standards of the IMO, and also considers the rules like DNV NAUT-AW and LR-IBS.

The system fulfills all requirements with regard to route planning, track keeping and monitoring as well as anti-grounding.

Ship sensor data (ARPA/AIS-targets, course, speed, position etc.) and sea charts can be observed simultaneously. The navigator has no longer to refer to the separate chart table which saves time and enables him to concentrate on his actual watchkeeping tasks.

This contributes substantially to greater safety in shipping and is therefore demanded for "Watch One" operations by leading classification societies (e.g. DNV, GL, LR).

The CHARTPILOT can operate with the following vector formats:

- "official" ENC (IHO-S57/Ed. 3.1)
- C-MAP CM-ENC
- C-MAP CM-93/2
- C-MAP CM-93/3 Professional and the raster formats:
- ARCS of British Admiralty

The CHARTPILOT is ready to support the Admiralty Vector Chart Service (AVCS) which has been recently introduced by the UKHO.

The presentation of the vector chart, as familiar to the navigator, is complemented by many further advantages over the paper chart, for instance: free selection of display scale, adapted quantity of display information, seamless chart coverage and simple information call for each object.

Owing to the completeness of its functions, the simplicity of operation and the flexibility with regard to system integration, the CHARTPILOT is a navigation system which is ideally suited for use on all new ships as well as retrofits irrespective of the type, class or size.

\* CHARTPILOT is used by courtesy of Cetrek Ltd., UK, the owner of the trademark registered in UK, USA and Japan





# Variety of Configurations

The CHARTPILOT also supports the C-MAP Real time Updating Service (RTU). It allows the CM-93/3 chart database and the official CM-ENCs to be updated instantly in real time via e-mail or the Internet, thus saving the mariner a lot of time and effort.

The CHARTPILOT is also an essential part of the Integrated Navigation System NACOS xx-5 (Navigation and Command System) as it supplies the RADARPILOT, MULTIPLOT, TRACKPILOT and the SPEEDPILOT with planning, track and map data.

The following versions are available:

## ■ Console versions

This version is normally integrated in the ship's operation console and supports the navigator directly in his ship handling tasks. All the functions associated with route monitoring, navigation and track keeping are performed here. The CHARTPILOT components can be delivered either in the design of the SCC-Ship Control Center or as individual components for integration into yard designed consoles.

## ■ Desktop versions

This version is typically accommodated in the chart table area for planning tasks. Interfacing with a digitizer allows the creation of "own" electronic charts or maps on the CHARTPILOT.

## ■ Dual workstation system

This configuration is used where full ECDIS back-up functionality is required, e.g. for IBS class-notation or for the replacement of official nautical paper charts.

## ■ Conning display

The Conning display provides the navigator with data of all relevant sensors as well as engine data and can be fitted either in the design of the SCC - Ship Control Center or as individual components for integration into yard designed consoles.

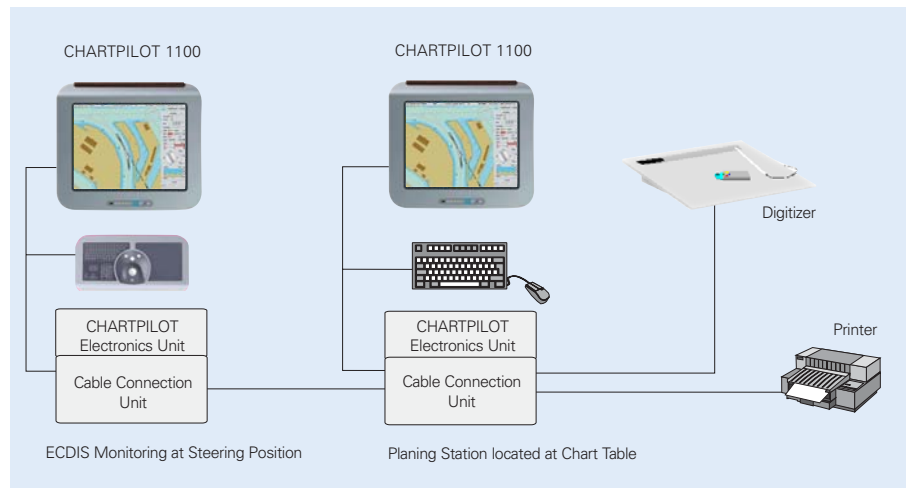

Typical dual ECDIS Back-up installation



# Overview of Functions

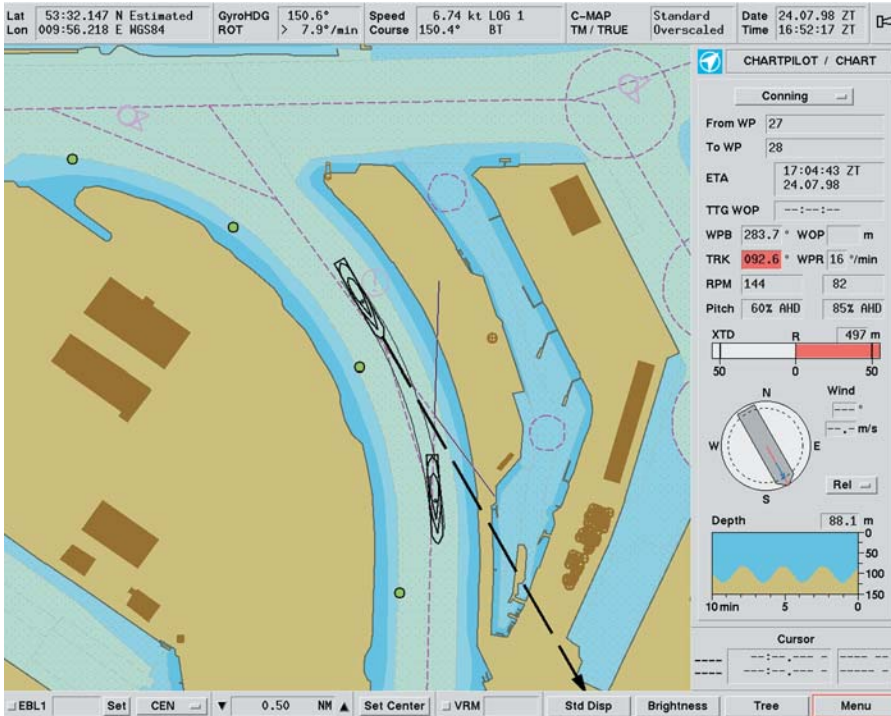

Route monitoring with conning display, Path Prediction activated (chart type: C-Map)

The main purpose of the CHARTPILOT is to support the navigator in his navigational tasks by combining nautical information, planned route data and geographical presentations against the background of the official Electronic Navigational Chart (ENC) or another digital chart.

The CHARTPILOT offers the following navigation and consulting functions:

## Data Management and Updating

Chart database manager: graphic interactive selection and loading of the following electronic chart standards:

- ENC: official vector data acc. IHO standard (S57 Ed. 3.1)
- CM-ENC: official vector data in C-MAP format
- CM-93: international vector database of C-MAP
- ARCS Raster Chart Data of British Admiralty\*
- Support of C-MAP Real Time Updating service

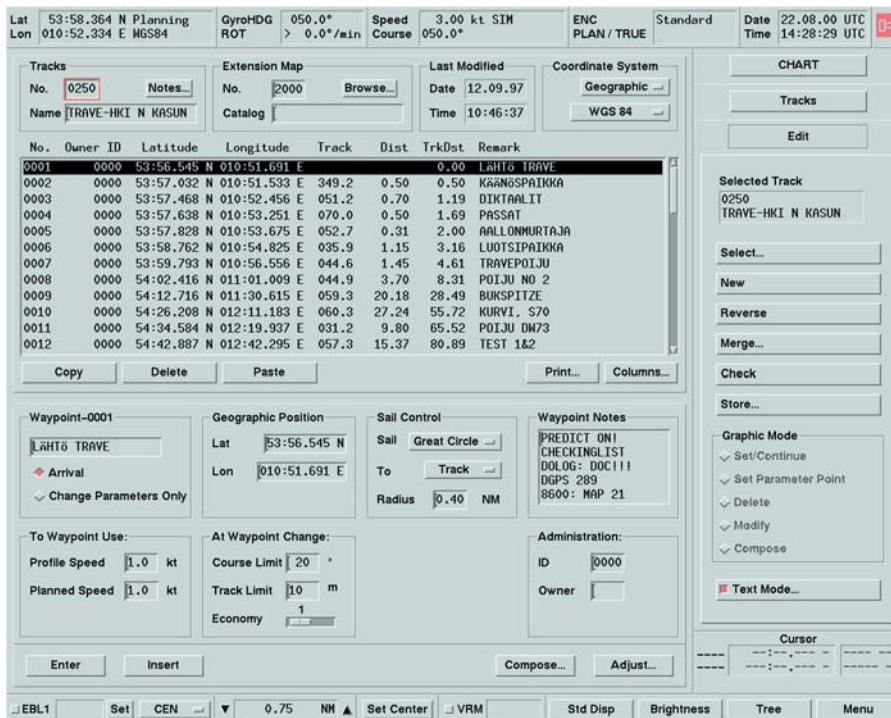

Numerical track planning

## Route Planning

The CHARTPILOT supports complete route planning with regard to waypoints, turn-radii and times, including a safety check of the planning data referred to the respective hydrography of the area.

- Graphic/numeric track/waypoint planning
- Track data for the adaptive autopilot/ track controller TRACKPILOT by input of the waypoints with pilot data:
  - Radius
  - Sail control (rhumb line, great circle, radius)
  - Track control mode
  - Course/track limit
  - Rudder economy
  - Planned/profile speed
  - Waypoint text info

\* Functions based on vector data are not available or maybe different with raster data.

- Generation of User Chart Objects
- Time-related track planning (graphic and alphanumeric)
  - Definition ETD/ETA for starting and end point of voyage including calculation of ETA and arrival speed for each waypoint (passage plan)
  - Definition of profile speed for each track section (controls the SPEEDPILOT)
- Combination of various track/waypoint files
- Reverse waypoint order
- Safety checks such as safety contour/depth alarm to avoid incorrect planning\*
- Transfer of Tracks and User Chart Objects to RADARPILOT 1100 and MULTIPILOT 1100
- Transfer of Vector Chart data to CHARTRADAR 1100

### Route Monitoring

- Various display modes
- Track Navigation/Conning Display
- Waypoint/Track Display
- Waypoint Approach-Window
- Track Alarm
- ARPA Alarm (TCPA/CPA)
- Depth Alarm
- Chart Alarm\*
- EVENT – display and storage of events and logbook notices
- Bearing Scale, Scale Bar
- Distance Rings (autom. scaled)
- VRM/EBL (ship-related or eccentric)
- Own ship symbol with scalable ahead vector and past/2nd past track
- Heading/Stern Line, Curved Headline and Path Prediction
- Display of ARPA /AIS targets with time-scalable past track and ahead vector
- 6 different day/night displays\*

### NAVTEX Display

In combination with DEBEG 2902 NAVTEX messages will be directly reported to the CHARTPILOT and displayed on user demand.

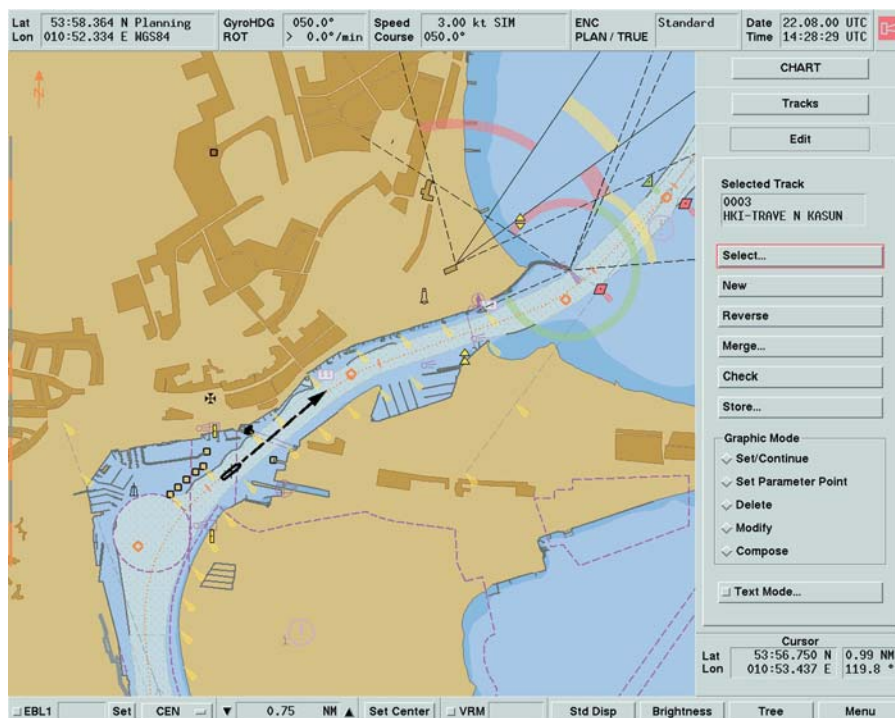

Graphical track planning (chart type: ENC)

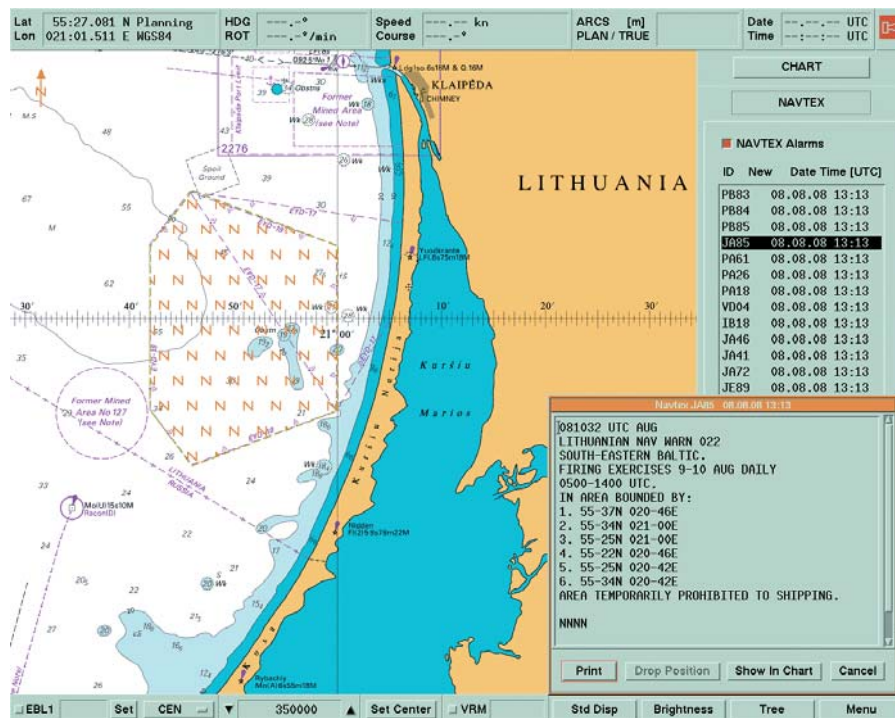

NAVTEX display with graphical indication on chart



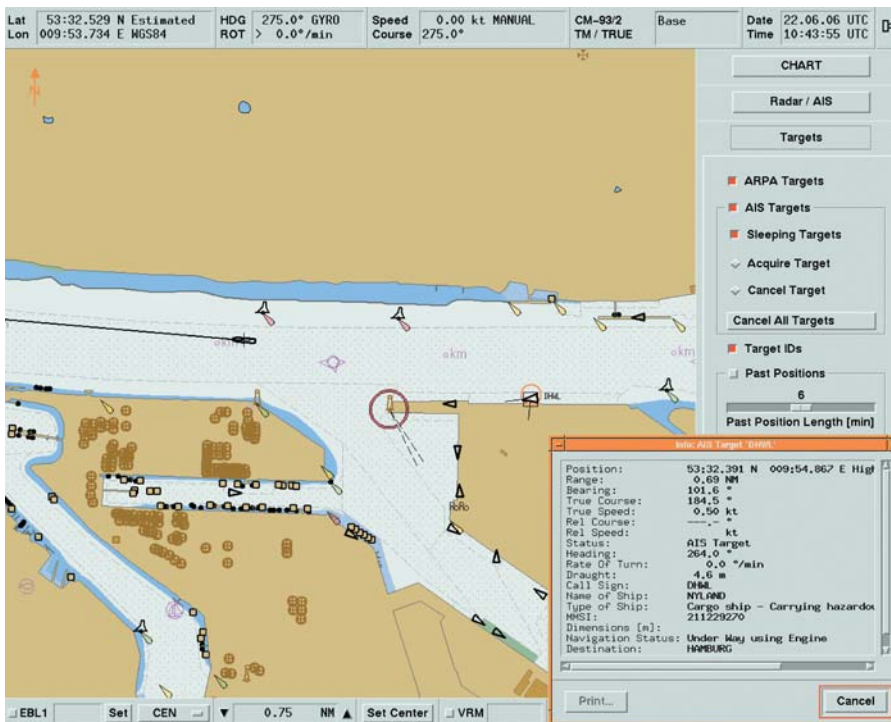

AIS information display (bright day presentation)

### AIS Information Display

If activated up to 40 AIS targets will be graphically displayed on the ECDIS screen including:

- Ship's identification
- Speed and course over ground
- Heading
- Rate of turn

Additional alphanumeric AIS data such as ship's name, Call sign, MMSI and other dynamic and voyage related information can be made available by the mariner on request.

If interfaced with AIS 3400/10 the CHARTPILOT 1100 is also approved as Minimum Keyboard Display for AIS.

### Conning Display

Central display of all navigation and manoeuvring data as well as engine and rudder data, e.g.:

- Heading, ROT
- Course, drift angle
- Off course, off track
- ETA, TTG
- Power, pitch, shaft\*\*
- Rudder, thruster\*\*
- Trim, heel\*\*
- Depth, wind

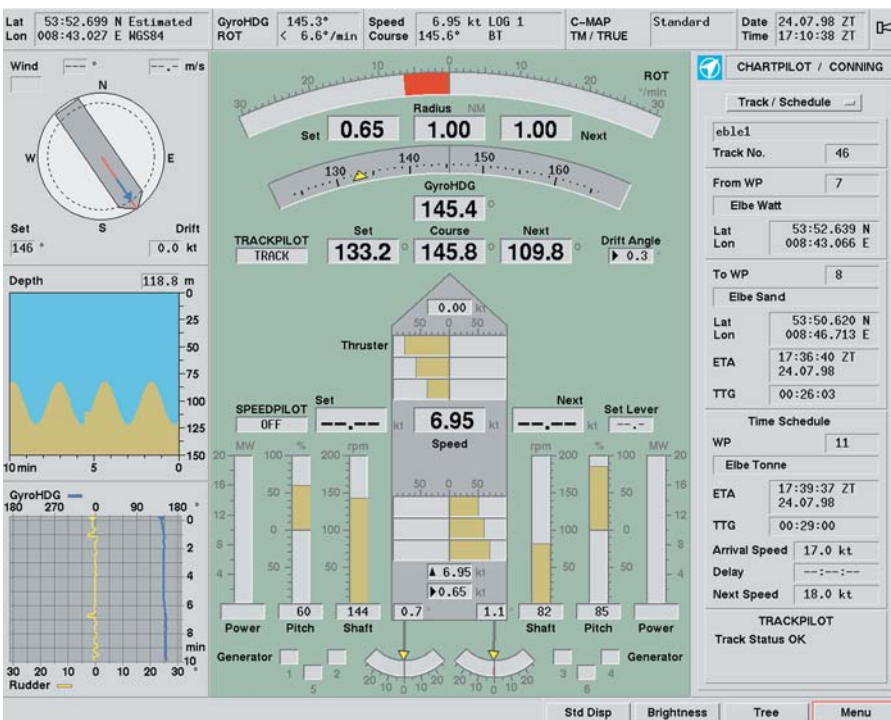

Conning display

### Consulting and Service Functions

- Text editor for notices, addresses, instructions ...
- Internal ship motion simulator for test and training purposes
- Nautical calculator
- Pilot card definition and printout
- Internal service program
- Storage and printout of all parameters and fixed values set in the entire NACOS system

\*\* If connected via the NACOS.

# Technical and Installation Data

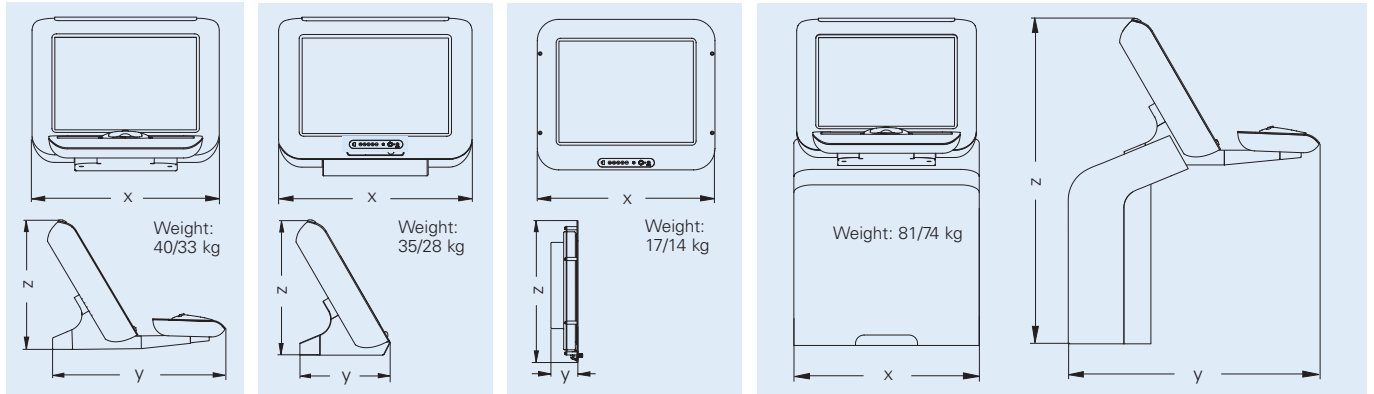

**C5 Desktop unit with integrated control panel**

**C5 Desktop monitor without control panel**

**C5 Console monitor**

**C5 Console unit with integrated control panel and display electronics**

## CHARTPILOT 1100 basic versions

Characteristics	Dimensions [mm]											
	C5 Console unit			C5 Desktop unit			C5 Desktop monitor			C5 Console monitor		
Size	x	y	z	x	y	z	x	y	z	x	y	z
19" TFT	650	887	1085	516	690	436	516	344	436	51	88	441
23" TFT	650	887	1168	630	690	519	630	344	519	630	102	534

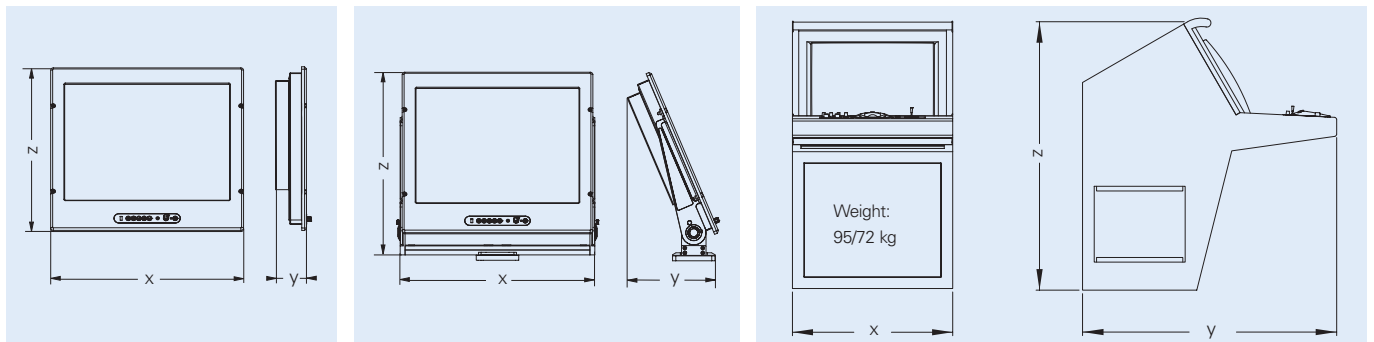

**C4 Console monitor**

**C4 Desktop monitor**

**C4 Console unit with integrated control panel and display electronics**

## CHARTPILOT 1100 basic versions

Characteristics	Dimensions [mm]								
	C4 Console unit			C4 Console monitor			C4 Desktop monitor		
Size	x	y	z	x	y	z	x	y	z
19" TFT	550	1090	1150	483	82	404	489	130	493
23" TFT	700	1090	1150	584	97	495	615	130	576

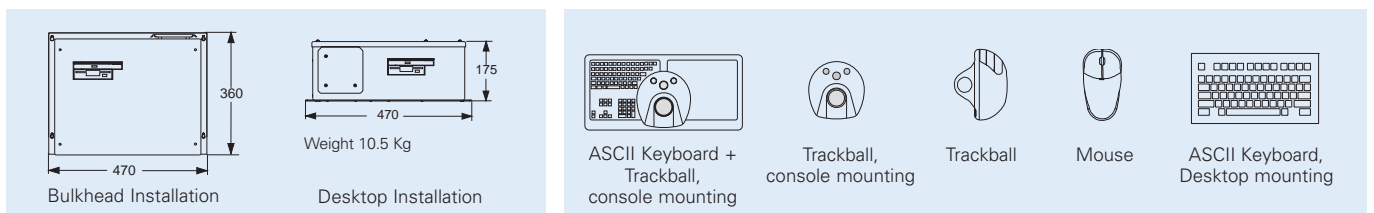

**Display electronics unit**

**Control panels and pointer devices**

# Technical and Installation Data

## Interfacing and Sensor Monitoring

Interfacing including numeric and graphic display of the following sensors:

- Position sensor
- Gyro/compass
- ROT indicator
- Doppler/EM speed log
- Echosounder
- AIS
- ARPA Radar
- NACOS
- Digitizer
- Printer
- Wind sensor
- Air humidity/pressure/temperature
- Monitoring of sensor data
- Integrated Data Recording with Play-back facility
- NAVTEX DEBEG 2902

## Equipment

### Monitor

- High Resolution
- 256 colors
- 19" TFT for desk top or console installation
- 23" TFT for desk top or console installation

### Processor Unit

- Intel CPU
- 40 GB Hard Disk Drive
- 3,5" Floppy Disk Drive
- CD/DVD Drive

### Control Unit

- Trackball for desktop or console installation
- ASCII keyboard for desktop or console installation

### Peripherals (optional)

- Printer
- A0 - A2 Digitizer
- UPS - Uninterruptible Power Supply

### Consoles

- Consoles 700, 650 mm and 550 mm width
- Desk top units 516 and 630 mm width
- Delivery of individual components for installation into shipyard consoles

### Power Supply

- 115/230 V, 47-63 Hz
- The CHARTPILOT processor electronics shall be supplied from an UPS source